



# HPRi Loudspeaker Accessory User Manual

## HPR YOKE 122 Yoke Bracket

### Introduction

This yoke mount is specifically for mounting the QSC HPR 122i loudspeaker to a structural support element (lighting or soundstage truss or other load bearing truss, etc.). Additionally, it may be used vertically oriented atop a 35mm loudspeaker pole mount allowing up- or down-tilt. It is not to be used as a wall mount or other attachment to non-load rated structure.

### Contents

- Steel Yoke Bracket (1)
- M10 Hex-head Bolts (2)
- Rubber Flat Washers (2)
- Steel Flat Washers (2)
- Steel Lock Washers (2)
- This User Manual

### Important Safety Information



**Do not use this yoke bracket to attach the HPR 122i to a wall or other architectural element!**

**Attach the base of this yoke bracket to the load-bearing structure using appropriate load-rated hardware approved for the application.**

**WARNING! Before placing, installing, rigging, or suspending any speaker product, inspect all hardware, suspension, cabinets, transducers, brackets and associated equipment for damage. Any missing, corroded, deformed or non-load rated component could significantly reduce the strength of the installation or placement. Any such condition severely reduces the safety of the installation and should be immediately corrected. Use only hardware which is rated for the loading conditions of the installation and any possible short-term unexpected overloading. Never exceed the rating of the hardware or equipment.**

**Consult a licensed, professional engineer when any doubt or questions arise regarding a physical equipment installation. Ensure all local, state, and national regulations regarding the installation, operation, and safety of this equipment are understood and adhered to.**

### Attaching the Yoke to the Loudspeaker

The yoke bracket is designed to attach only to the side rigging points on the loudspeaker as shown in Figure 1.

1- To attach the bracket to the loudspeaker enclosure, you must first remove the M10 bolts from the enclosure's side rigging points (6mm hex wrench required).

2- Attach the yoke to the rigging points using the M10 Hex Head Bolts included with the bracket. Note the hardware order shown in Figure 2. Ensure the rubber flat washers are installed between the bracket and the loudspeaker enclosure. The steel flat and lock washers are to be installed between the bolt and the outside bracket surface. The lock washer is the outermost washer, located directly under the head of each bolt.

3- Tighten bolts snugly, just to the point where the yoke is held in place but able to rotate. Set desired tilt and tighten the two M10 bolts to secure the loudspeaker in place.

Figure 1- Attach yoke bracket to the side rigging points.

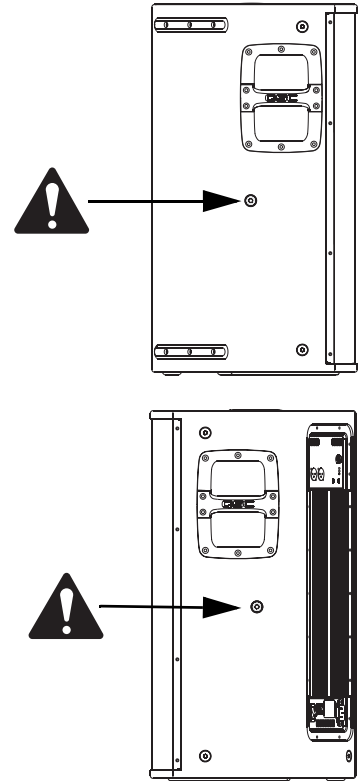
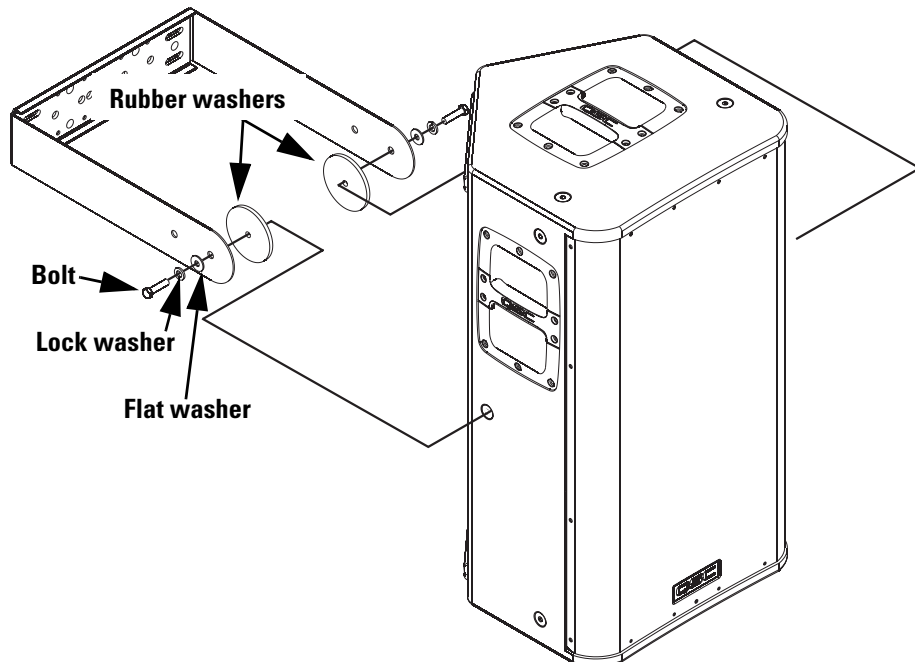


Figure 2- Hardware installation order.



## Installation Options

The yoke bracket can be used to support the HPR 122i in several ways.

**Yoke above loudspeaker enclosure (Figure 3)** - If using the yoke bracket positioned above the enclosure, attach to the enclosure using the outermost set of mounting holes in the bracket's arms.



**If single point bracket attachment to the support structure is used, ensure the support hole just right of the loudspeaker's centerline is used in order to keep the enclosure's weight balanced.**

**Yoke below loudspeaker enclosure (Figure 4)** - If using the yoke bracket positioned below the enclosure, attach the yoke to the enclosure using either set of mounting holes in the bracket's arms.

**Yoke behind loudspeaker enclosure (Figure 5)** - If using the yoke bracket positioned behind the enclosure, use the innermost set of mounting holes in the bracket's arms. Do not use the outermost set of holes!



**If the yoke bracket is behind the loudspeaker, the inner set of mounting holes (on the brackets arms) must be used.**

**Third party loudspeaker pole stand mount (Figure 6)** - The yoke bracket may be attached to a third party loudspeaker pole stand mount. This allows the user to mount the HPR 122i on a 35mm loudspeaker pole and be adjusted for up- or down-tilt, as required. The bracket's mounting hole pattern fits most available mounts. For a list of compatible pole mounts, please visit <http://www.qscaudio.com>.



**When attaching the pole mount, use the pole mount holes that result in the center of the pole being offset to the right of the loudspeaker's centerline (as viewed from the front of the enclosure).**

**Do nothing-** Keep in mind, if you do not know what you are doing, don't mount this loudspeaker to anything, including the yoke bracket. Consult professional assistance if unsure about any loudspeaker mounting or suspension topic or procedure.

## Warranty

(USA only; other countries, see your dealer or distributor)

### Disclaimer

QSC Audio Products, Inc. is not liable for any damage to amplifiers, or any other equipment that is caused by negligence or improper installation and/or use of this loudspeaker product.

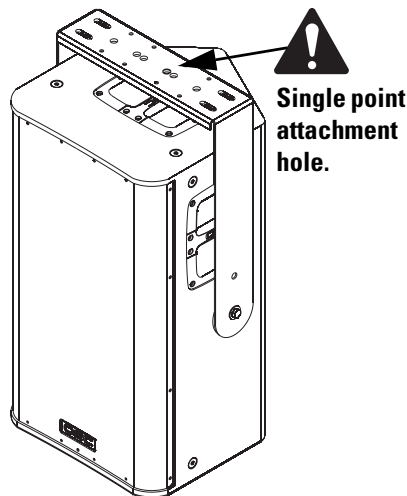
### QSC Audio Products 3 Year Limited Warranty

QSC Audio Products, Inc. ("QSC") guarantees its products to be free from defective material and / or workmanship for a period of three (3) years from date of sale, and will replace defective parts and repair malfunctioning products under this warranty when the defect occurs under normal installation and use - provided the unit is returned to our factory or one of our authorized service stations via pre-paid transportation with a copy of proof of purchase (i.e., sales receipt). This warranty provides that the examination of the return product must indicate, in our judgment, a manufacturing defect. This warranty does not extend to any product which has been subjected to misuse, neglect, accident, improper installation, or where the date code has been removed or defaced. QSC shall not be liable for incidental and/or consequential damages. This warranty gives you specific legal rights. This limited warranty is freely transferable during the term of the warranty period.

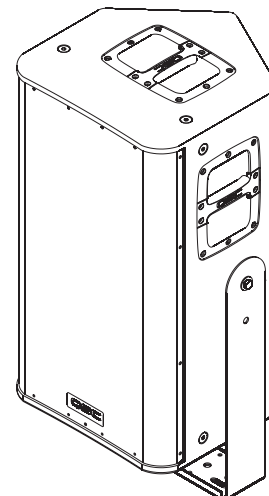
Customer may have additional rights, which vary from state to state.

In the event that this product was manufactured for export and sale outside of the United States or its territories, then this limited warranty shall not apply. Removal of the serial number on this product, or purchase of this product from an unauthorized dealer, will void this limited warranty. Periodically, this warranty is updated. To obtain the most recent version of QSC's warranty statement, please visit [www.qscaudio.com](http://www.qscaudio.com). Contact us at 800-854-4079 or visit our website at [www.qscaudio.com](http://www.qscaudio.com).

**Figure 3- Yoke above enclosure.**

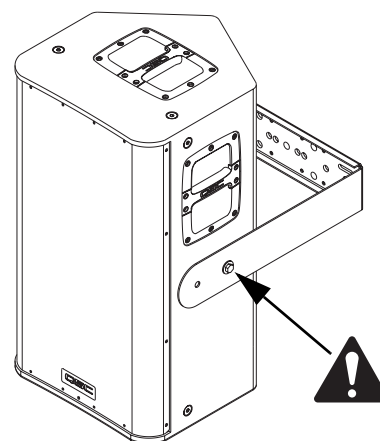


**Figure 4- Yoke below enclosure.**



**Figure 5- Yoke behind enclosure.**

**Note! Use inner set of mounting holes for attaching enclosure to bracket arms.**



**Figure 6- Yoke mounted on third-party loudspeaker pole mount.**

**Note! Use the pole mount holes (shown) to the right of the loudspeaker's centerline as viewed from the front of the enclosure. This will better balance the loudspeaker over the pole.**

